

Cambridge Secondary 1 Progression Test

Question paper

Cambridge
Secondary 1

45 minutes

Science Paper 1

Stage 8

Name

Additional materials: Ruler
Calculator

READ THESE INSTRUCTIONS FIRST

Answer **all** questions in the spaces provided on the question paper.

You should show all your working on the question paper.

The number of marks is given in brackets [] at the end of each question or part question.

The total number of marks for this paper is 50.

For Teacher's Use	
Page	Mark
1	
2	
3	
4	
5	
6	
7	
8	
9	
10	
11	
12	
13	
14	
Total	

* 0 7 4 3 4 3 0 9 7 2 *

- 1 The diagram shows part of the circulatory system.

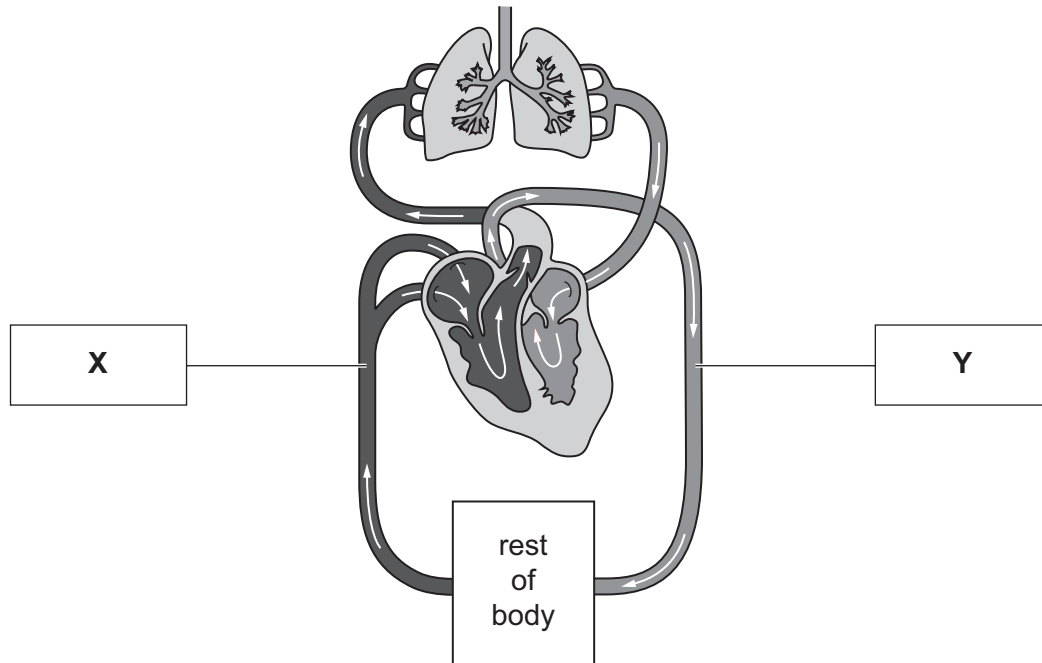

- (a) Name the **types** of blood vessels labelled **X** and **Y** in the diagram.

X

Y

[2]

- (b) Name the **organ** where gaseous exchange takes place.

.....[1]

- 2 (a) Draw a straight line between the **name** of the element and its **chemical symbol**.

For
Teacher's
Use

name	chemical symbol
	Al
neon	Na
sodium	Ar
nitrogen	Ne
aluminium	N
	S

[4]

- (b) Circle the **two** elements which are metals.

aluminium neon nitrogen sodium

[2]

- (c) Give **three** properties of metals.

1.....

2.....

3.....

[3]

3 Janka has a bar magnet.



She hangs the bar magnet from a wooden clamp stand.

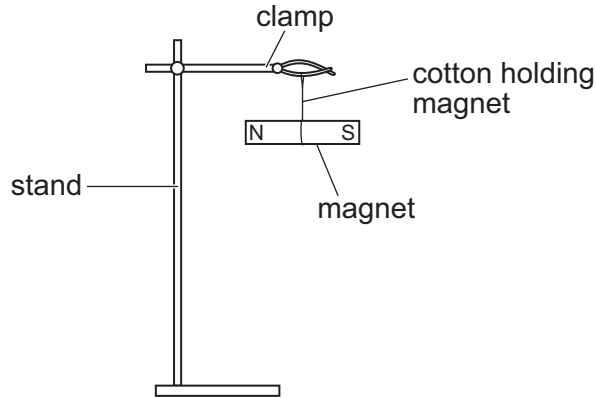

Janka brings another bar magnet towards the hanging magnet.

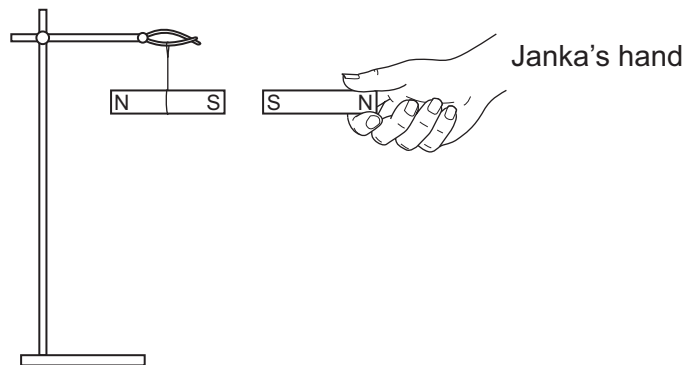

(a) Explain what happens.

.....
 [2]

(b) Janka repeats the experiment using an iron stand.

Describe how the hanging magnet is affected by the iron stand.

..... [1]

4 This diagram shows the human alimentary canal.

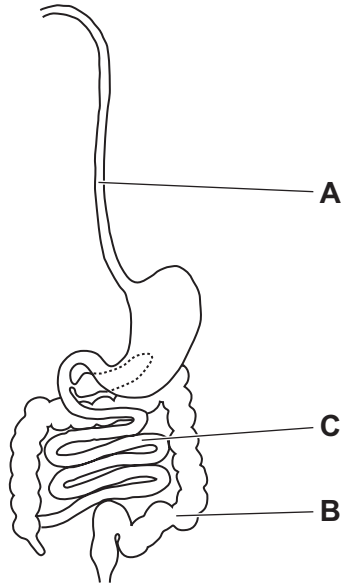

(a) Name the parts labelled **A** and **B**.

A

B

[2]

(b) Write down **one** function of the small intestine **C**.

.....

.....

..... [1]

5 Brigitte plays a musical instrument called a saxophone.
Her teacher asks her to explain the sound the saxophone makes.

(a) Complete the sentences that Brigitte writes.

Choose from the following words.

- | | | |
|-----------------|-----------------|----------------|
| contract | energy | expand |
| force | particle | vibrate |

Sound is a type of

Sound is made when the particles in the air [2]

(b) Brigitte plays a note on her saxophone.

The diagram shows the pattern the note makes on the oscilloscope.

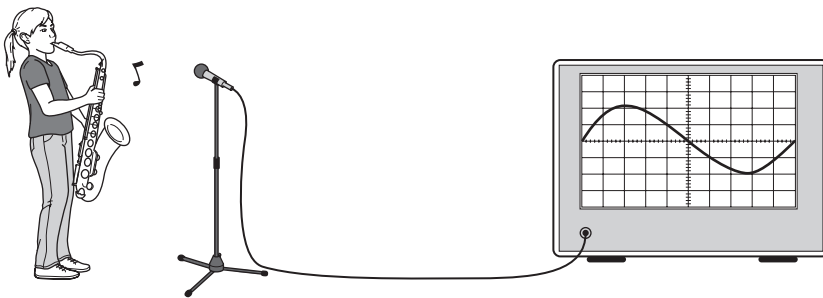

NOT TO SCALE

Here are some oscilloscope pictures of different notes from Brigitte's saxophone.

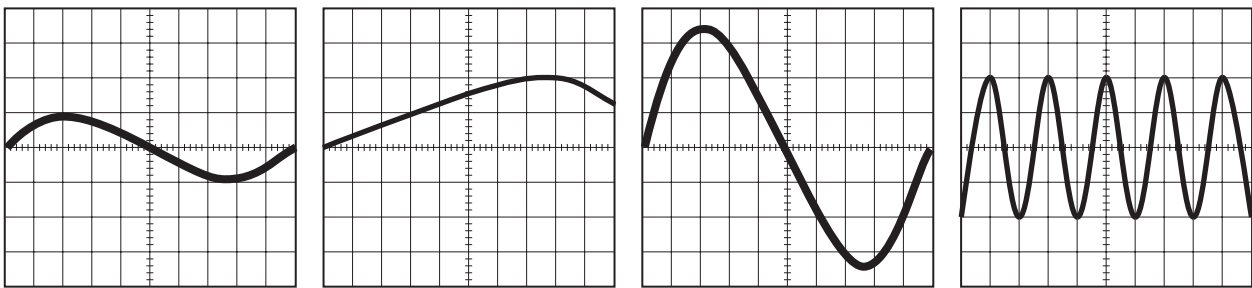

A

B

C

D

(i) Which note has the **highest** pitch?

Circle the correct answer.

A

B

C

D

[1]

(ii) Which note is the **loudest**?

Circle the correct answer.

A

B

C

D

[1]

(iii) Brigitte plays one note quietly and then makes this note louder.

Draw the oscilloscope picture you would see.

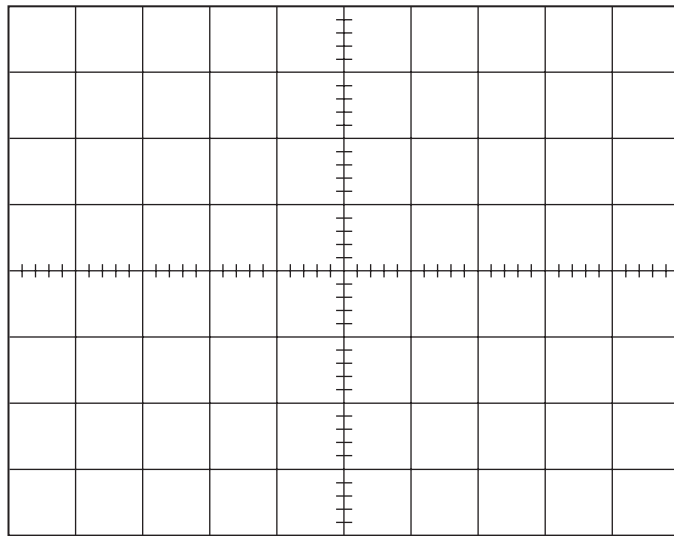

[2]

For
Teacher's
Use

- 6 Usman trains to run a 1 km race.
He measures his heart rate while running.
Here are his results.

time in minutes	heart rate in beats per minute
0	90
1	120
2	
3	160
4	175
5	190
6	200
7	210
8	210

- (a) Plot the results for heart rate on the grid below.

Four of the points have been plotted for you.

Label **both** axes.

Draw a smooth curve through the points.

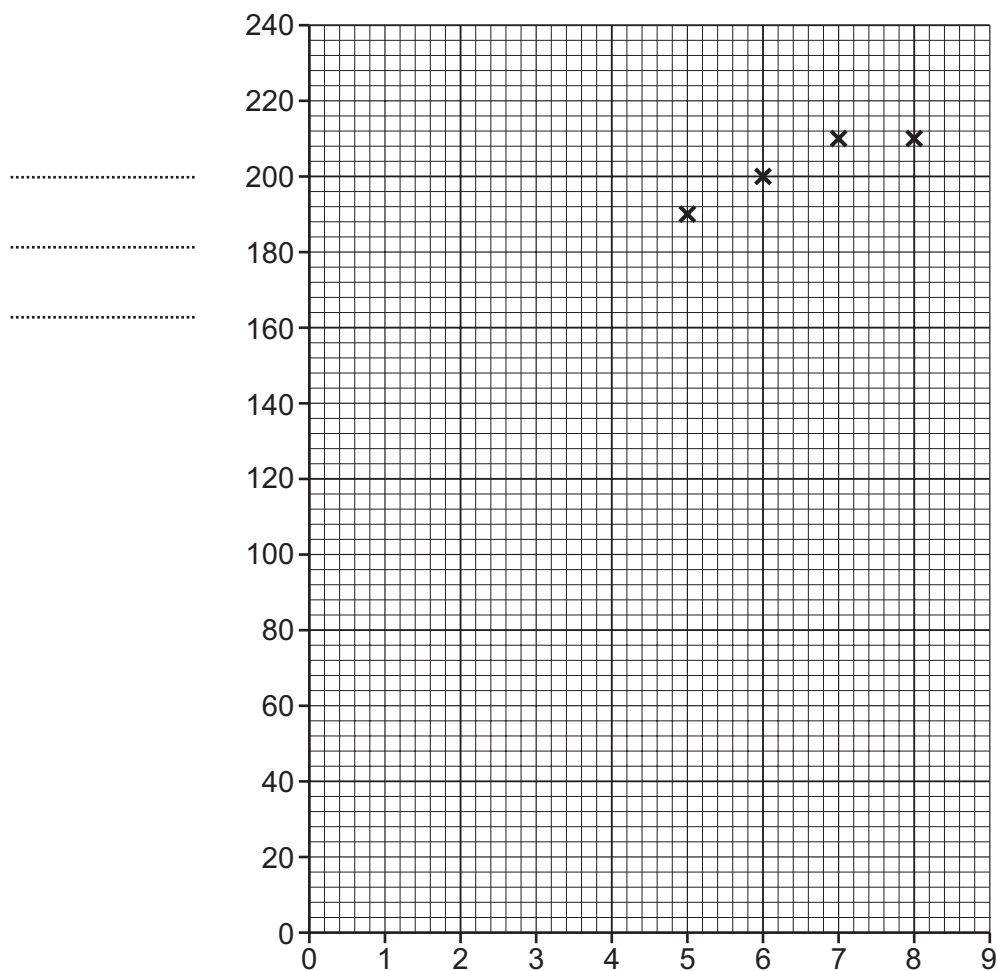

[4]

(b) Use your graph to predict Usman's heart rate at time 2 minutes.

..... beats per minute [1]

(c) Explain why Usman's heart rate increases during exercise.

.....
.....
..... [2]

For
Teacher's
Use

7 Bruce compares the speeds of some toys down a ramp.

Here is the equipment he uses.

For
Teacher's
Use

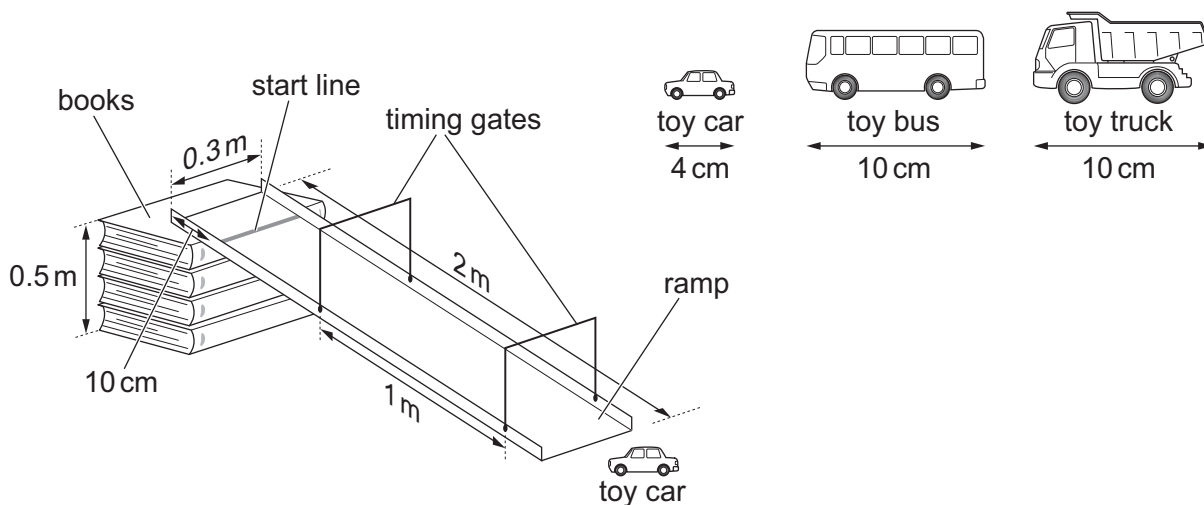

He places each toy on the start line and then lets the toy go.

Here are his results.

toy	mass of toy in grams	distance between timing gates in metres	height of books in centimetres	length of ramp in metres	time taken to travel between timing gates in seconds
bus	400	1.0	50	2.0	1.78
car	100	1.0	50	2.0	0.95
truck	400	1.0	50	2.0	2.50

(a) Bruce keeps some variables the same.

Write down **two** variables he keeps the same.

1.....

2..... [2]

(b) (i) Which **two** measurements are needed to work out the average speed of the toy truck?

1

2 [2]

(ii) Work out the average speed of the toy truck.

Include the correct units in your answer.

speed = [3]

- 8 (a) Mariana makes a poster showing different types of substances for a school project.

The labels on her poster are missing.

Write the correct label under each diagram.

Choose from the following words.

compound

element

mixture

You can use each word once, more than once or not at all.

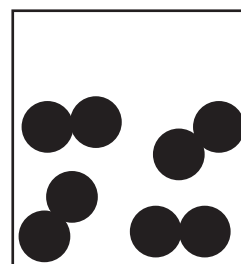
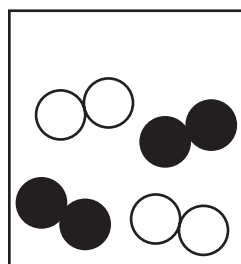
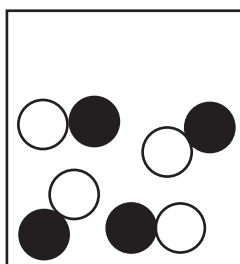
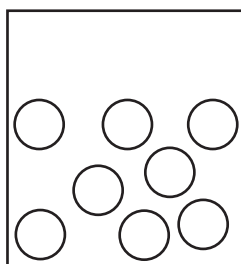

.....

.....

.....

.....

[4]

- (b) Hydrogen and oxygen react together to make water.

Write a **word equation** for this reaction.

.....[2]

- 9 This question is about human reproduction.

- (a) Put these sentences in the correct order.

Use the numbers **1** to **5**.

One is done for you.

If an egg is present the sperm enters the egg.	
The journey continues into the oviduct (fallopian tube).	
Sperm is deposited in the vagina.	1
Sperm travels through the cervix.	
Sperm swim across the uterus (womb).	

[2]

(b) Here is a diagram of a sperm cell.



(i) Label the part used for movement with an **A**. [1]

(ii) Label the part containing the genetic information with a **B**. [1]

(c) A woman can sometimes release two different eggs at the same time.

Write down what will happen if sperm cells enter both of these eggs.

.....

.....

..... [2]

BLANK PAGE

Permission to reproduce items where third-party owned material protected by copyright is included has been sought and cleared where possible. Every reasonable effort has been made by the publisher (UCLES) to trace copyright holders, but if any items requiring clearance have unwittingly been included, the publisher will be pleased to make amends at the earliest possible opportunity.

Cambridge International Examinations is part of the Cambridge Assessment Group. Cambridge Assessment is the brand name of University of Cambridge Local Examinations Syndicate (UCLES), which is itself a department of the University of Cambridge.